

**Provided for non-commercial research and education use only.
Not for reproduction, distribution or commercial use.**

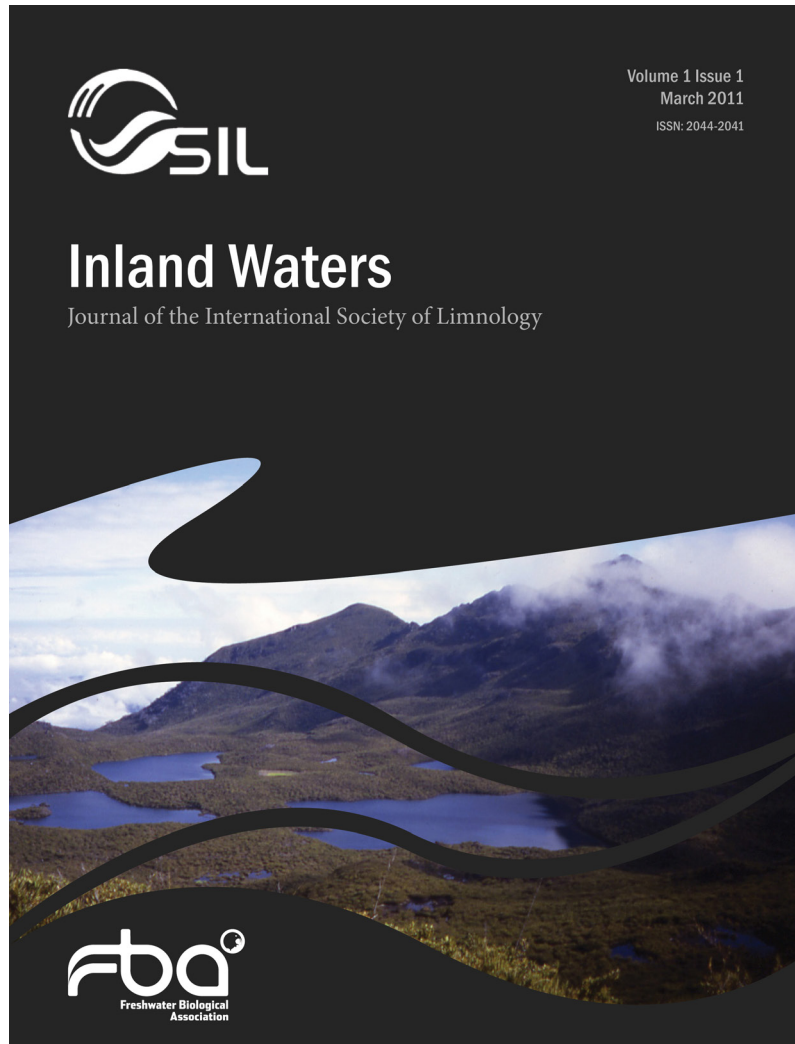

This article appeared in *Inland Waters* - Journal of the International Society of Limnology, published by The Freshwater Biological Association. The attached offprint is provided to the author for research and education use (including use by others within their institution for such purposes) and for sharing with interested colleagues, provided the use of the article is for non-commercial purposes, and copies offered are not for sale and are not distributed in a systematic way.

Please note that posting of the published version of the article to personal/academic websites or institutional repositories is not permitted, except for authors who have paid an 'open early' fee. All authors are permitted to post the submitted version of their manuscript (as prior to peer-review), provided it is clearly stated that the manuscript is unpublished, and full bibliographic reference to the published article is given. Authors who have paid an 'open early' fee are permitted to post the final published version of the article to their personal/academic website or institutional repository, provided that it is non-commercial and there is a link to the published article on the journal website, <https://www.fba.org.uk/journals/index.php/IW>.

Scaling relationships among drivers of aquatic respiration in temperate lakes: from the smallest to the largest freshwater ecosystems

E.K. Hall,^{1*} D.R. Schoolmaster Jr.,² A.M. Amado,³ E.G. Stets,⁴ J.T. Lennon,⁵ L.M. Domine,⁶ and J.B. Cotner⁷

¹ *Natural Resource Ecology Laboratory Colorado State University, Fort Collins, CO, USA*

² *US Geological Survey, National Wetlands Research Center, Lafayette, LA, USA*

³ *Limnology Laboratory, Departamento de Oceanografia e Limnologia, Pós-graduação em Ecologia, Universidade Federal do Rio Grande do Norte, Natal, Brazil*

⁴ *US Geological Survey, Boulder CO, USA*

⁵ *Department of Biology Indiana University, Bloomington, IN, USA*

⁶ *Department of Biology, University of St. Thomas, St. Paul, MN, USA*

⁷ *University of Minnesota, Department of Ecology, Evolution and Behavior, St. Paul, MN, USA*

* *Corresponding author: ed.hall@colostate.edu*

Received 24 February 2015; accepted 8 July 2015; published 23 December 2015

Abstract

To address how various environmental parameters control or constrain planktonic respiration (PR), we used geometric scaling relationships and established biological scaling laws to derive quantitative predictions for the relationships among key drivers of PR. We then used empirical measurements of PR and environmental (soluble reactive phosphate [SRP], carbon [DOC], chlorophyll *a* [Chl-*a*]), and temperature) and landscape parameters (lake area [LA] and watershed area [WA]) from a set of 44 lakes that varied in size and trophic status to test our hypotheses. We found that landscape-level processes affected PR through direct effects on DOC and temperature and indirectly via SRP. In accordance with predictions made from known relationships and scaling laws, scale coefficients (the parameter that describes the shape of a relationship between 2 variables) were found to be negative and have an absolute value <1. Biological parameters scaled positively with physical and chemical processes in accordance with those predicted from theory or previous studies (i.e., temperature >1, others <1). We also found evidence of a significant relationship between temperature and SRP. Because our dataset included measurements of respiration from small pond catchments to the largest body of freshwater on the planet, Lake Superior, these findings should be applicable to controls of PR for the great majority of temperate aquatic ecosystems.

Key words: aquatic respiration, ecosystem size, lake area, planktonic respiration, scaling, watershed area

Introduction

The need to define the controls and constraints on planktonic respiration (PR) and estimate to what extent those controls are applicable to the majority of lakes is a major research challenge in aquatic ecosystem ecology today. It is becoming increasingly evident that inland waters are a highly reactive component in the global carbon cycle. While large lakes integrate inputs from larger landscapes, lake area distribution is skewed toward

smaller lakes where carbon cycling is more intensive (Winslow et al. 2014). These small systems have a cumulative global lake surface area much larger than originally estimated (Downing et al. 2006, McDonald et al. 2012, Winslow et al. 2014). This finding, in combination with the more recent recognition of the contribution of lotic ecosystems to atmospheric carbon dioxide (Battin et al. 2008, Raymond et al. 2013), has led to the call for a better integration of inland waters into the global carbon budget (Cole et al. 2007, Battin et al. 2009).

Whereas benthic respiration is an important pathway of carbon mineralization (Gudas et al. 2010), water column respiration is on average 7-fold greater than the rate of benthic respiration (Pace and Prairie 2005) and therefore is the major pathway for organic carbon mineralization in lentic ecosystems.

To be broadly applicable, controls and constraints on PR must have similar relationships across a broad range of lakes that vary in trophic state and size. A previous synthesis of published freshwater PR values ($n = 67$) found that chlorophyll *a* (Chl-*a*) was the best predictor of PR in lakes, with temperature and dissolved organic carbon (DOC) having less but still significant explanatory power (Pace and Prairie 2005). Although Chl-*a* is a biological variable that responds to multiple environmental drivers, regionally DOC in lakes is controlled by landscape variables such as slope (Mann et al. 2012), percent wetland area (Qualls and Richardson 2003), precipitation (Mattsson et al. 2008), and more generally total watershed area (WA) and lake area (LA). Similarly, temperature is primarily influenced by LA and depth, which for glacial lakes tend to be proportional (Kalf 2001).

Decades of work have led to the general understanding that processes and characteristics of upland ecosystems (i.e., the watershed) have important implications for freshwater ecosystems that lay lower in the landscape (Vannote et al. 1980, Kratz et al. 1997). One example of watershed influences on freshwater ecosystems is inputs of dissolved organic matter (DOM) and mineral nutrients such as nitrogen (N) and phosphorus (P), which fuel heterotrophic lake metabolism. Specifically, bacterial respiration (BR), an important component of PR, is influenced by terrestrial inputs of DOM (Karlsson et al. 2004). In addition, it is well established that allochthonously derived inorganic and organic N and P also support planktonic metabolism (Cole et al. 2007). Because both organic and inorganic terrestrial subsidies are important to lake heterotrophy and are driven by landscape characteristics (Hanson et al. 2003, McCallister and del Giorgio 2012), WA and LA have been suggested as potential metrics that may scale with drivers of aquatic metabolism (Canham et al. 2004). All else being equal, the larger the WA, the greater the mass load of allochthonous subsidies; however, the effect of these subsidies has been noted to decrease with increasing LA as the inputs become a smaller proportion of the volume of the lakes (Biddanda et al. 2001). To date, a synthesis of how such allochthonous and autochthonous mechanisms affect PR has been elusive. Scaling laws developed for both physical and biological relationships have a successful history that allows predictions of entities across broad scales where continuous measurements are not always possible. Here we derive scaling laws from first principles to see if they

can provide insight into how landscape characteristics relate to the water characteristics likely to drive lake metabolism.

In physical systems, processes can be related to one another by scaling relationships of the form

$$Y = aX^b \quad (1)$$

In many cases, geometric or physical constraints are used to predict the scaling constant (McMahon 1973, West et al. 1997), which determines the nature of the nonlinearity between Y and X (Fig. 1). In biological systems there are many examples of scaling relationships, including Kiebler's allometry, which relates animal metabolic rate to body size; Fenchel allometry, which relates reproductive rate to body size; and Damuth allometry, which relates density of mammals and birds to body size (reviewed in Ginzburg and Colyvan 2004). Ecosystem-level scaling relationships depend, however, on a complex combination of biological, chemical, and physical constraints, potentially making their scaling constants harder to predict from first principles.

To understand general relationships between PR and its drivers, we derived the scaling relationships between landscape-level features and PR from first principles. We hypothesized that the effect of landscape processes on respiration were mediated through within-lake physical and chemical processes (Fig. 2a). Because many of the putative drivers of respiration are ultimately derived from the watershed (i.e., allochthonous inputs), we used the hypothesized scaling relationships between landscape variables and drivers of respiration to inform the expected sign and magnitude of the relationships among within-lake parameters and PR (Fig. 2b).

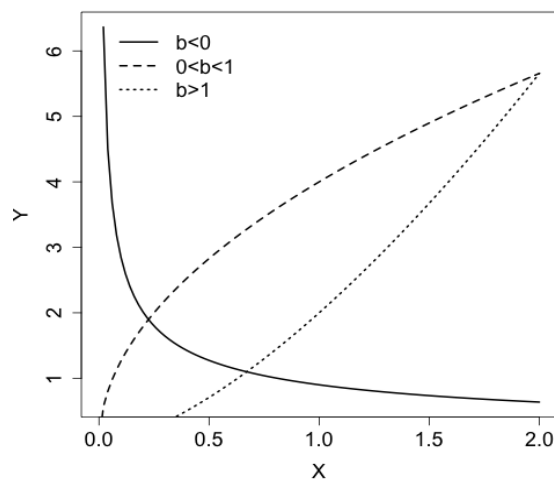

Fig. 1. Example of the nonlinear behavior of the relationship $Y = aX^b$, given values of the scaling coefficient b in different ranges and assuming $a > 0$.

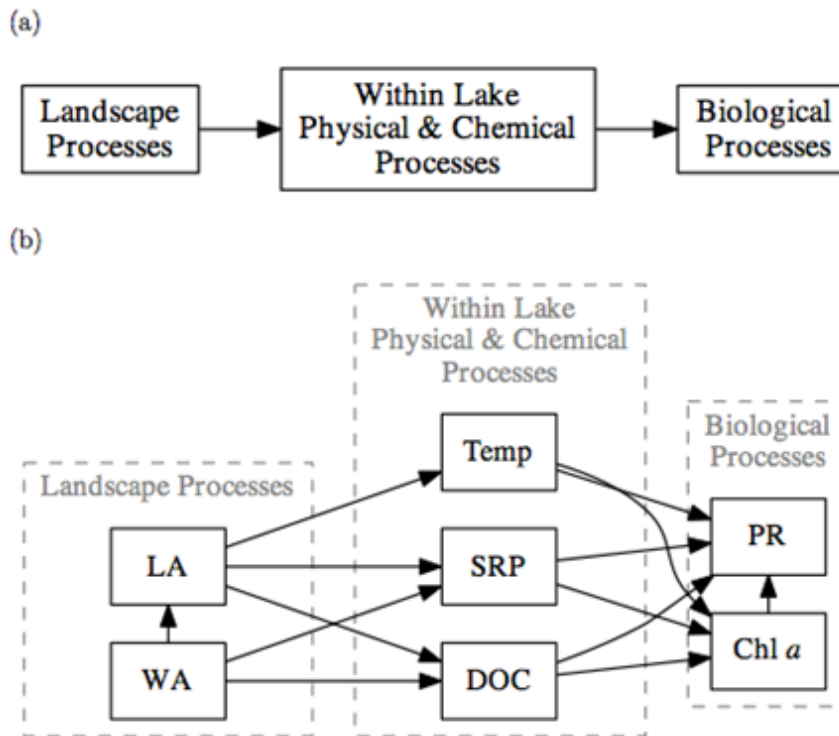

Fig. 2. (a) Conceptual model of how the causal effects of watershed characteristics on PR are mediated through physical, chemical and biological properties within the lake; (b) an *a priori* causal hypotheses relating specific landscape and within-lake variables.

Specifically, we used 2 landscape parameters: WA and LA; 3 physical/chemical variables: soluble reactive phosphorus (SRP), water temperature, and DOC; and 1 biological variable: Chl-*a*, to derive the direction and magnitude of their relationships among each other and to PR.

Deriving proportional relationships among drivers of respiration

WA sets a constraint on the upper limit of the LA within it; therefore, because $WA \propto L^2$, where L is a one-dimensional measure of watershed such as length, $LA \propto L^2$. Substituting the relationship between WA and L^2 for L^2 gives

$$LA \propto WA. \tag{2}$$

Scaling landscape parameters with chemical and physical drivers

If we assume that the majority of chemical nutrients (DOC and SRP) enter the system from the outer boundary (i.e., the watershed) the inputs (I) should scale with the square of the single dimensional measure of watershed

size such as diameter (i.e., $I \propto L^2$) for a given geographical region. For a given rate of input, the concentration C should scale as $C \propto \frac{I}{L^3}$, where L^3 is lake volume. Substituting for I gives $C \propto \frac{L^2}{L^3}$ or, equivalently, $C \propto \frac{1}{L}$. Because, as shown above, LA scales with the square of watershed diameter, $LA \propto L^2$, we can solve for the scaling between concentration and LA or WA area by substitution. For example, rewriting the lake area relationship in terms of L , instead L^2 gives $L \propto \sqrt{LA}$. Substituting this relationship into the one for concentration gives $C \propto \frac{1}{\sqrt{LA}}$ or $C \propto LA^{-1/2}$. Thus, if our assumptions about the geometry of inputs hold, we predict that scaling constants among DOC and SRP with LA should be negative and have an absolute value <1. Similarly, temperature should scale with LA (temperature $\propto LA$) because larger lakes are on average deeper and colder. For large shallow lakes this may not be the case; however, lakes of glacial origin that dominated the current study (and the majority of temperate lakes) tend to have a proportional relationship between LA and depth. Many other factors, such as latitude, also affect lake temperature, but as long as those factors do not also affect LA, they will not affect the scaling relationship, only the residual error. Thus, we predicted temperature to scale negatively with LA as temperature $\propto LA^{-1}$.

Scaling physical and chemical drivers with biological variables

In biological systems, constraints due to the geometry of body size and resource uptake suggest that population density and respiration should scale with nutrients with coefficients >0 but <1 (Enquist et al. 1998). Therefore, the temperature dependence of biochemical reactions on temperature (sometimes expressed as Q_{10} , the log of the magnitude of change in a rate per $10\text{ }^{\circ}\text{C}$ change in temperature), respiration, and Chl-*a* (assuming that Chl-*a* is a reasonable proxy for algal biomass) should scale positively with temperature with a coefficient >1 . Although Q_{10} may be a poor index of temperature dependence of mixed microbial communities (Hall and Cotner 2007) and clearly varies across a range of temperatures (Montagnes et al. 2003), it is still reasonable to use Q_{10} as a proportional constraint for the relationship between temperature, algal biomass, and PR.

We tested each of these hypothesized scaling relationships using direct measurements of PR from a series of temperate lakes (Supplementary Table S1), including Lake Superior, to assess if these theoretically derived scaling relationships were consistent with those derived empirically.

Materials and methods

Ecosystem characteristics

We analyzed 60 measurements of PR from 44 bodies of water with a broad range of trophic states, temperatures, and sizes (Table 1). This range and diversity of ecosystems provided a unique opportunity to test general, broadly applicable patterns with the goal of adding insight into the relationships between landscape basins and ecosystems processes.

Field sampling and chemical analyses

Water was collected from the sampling site and placed directly into 300 mL glass bottles with ground-glass tops. For all measurements, PR was determined as the decrease in dissolved oxygen concentration over time, with oxygen content measured in triplicate BOD bottles using Winkler titrations (Wetzel and Likens 2000). All incubations were conducted either in water baths or temperature controlled incubators. Water temperature of the bath or air temperature of the incubator was checked at the beginning and end of the experiment and stayed within $\pm 2\text{ }^{\circ}\text{C}$ over the course of the incubation. Incubations were carried out for $\sim 12\text{ h}$; for ultra-oligotrophic lakes (e.g., Lake Superior)

the incubation was extended to 96 h to ensure a clear difference in dissolved oxygen could be detected.

Over the course of 2 ice-free seasons we sampled ~ 43 lakes in the Upper Midwestern United States between June and August, as described elsewhere (Hall et al. 2009). During the stratified period, we obtained water samples from the mixed layer at the deepest point in the lake (or the approximate center if the bathymetry was unknown) and from the upper third of the water column when the lake was unstratified (Hall et al. 2009). We also sampled the western arm of Lake Superior at 5 pelagic sites during 3 cruises (R/V Blue Heron, University of Minnesota; Aug, Sep, and Oct 2006) just below the surface ($\sim 1\text{ m}$) using a Rosette sampler totaling 15 observations. We filtered all dissolved nutrient samples through a 47 mm glass fiber (GF/F) filter ($0.7\text{ }\mu\text{m}$ nominal cut-off) at low pressure ($<100\text{ mm Hg}$); samples were frozen until analyses. We analyzed filtered water samples colorimetrically for SRP without digestion (APHA 1992) and DOC using a Shimadzu TOC 5000. Water samples were also filtered onto GF/F filters for collection of algal biomass and subsequent analysis of Chl-*a*. All filters were kept frozen in the dark until analysis. Pigments were extracted in 90% acetone, determined fluorometrically, and calibrated with a Chl-*a* standard (extracted from spinach) in a Turner Designs 10-AU Fluorometer (Parsons et al. 1984).

Lake and watershed area

We quantified LA and WA for lakes located in Minnesota and Wisconsin, determining LA using geographic databases maintained by the state Department of Natural Resources (http://deli.dnr.state.mn.us/data_search.html and <http://dnr.wi.gov/maps/gis/>). In South Dakota, LA was obtained from the National Hydrography Dataset (<http://nhd.usgs.gov/>). WA was calculated using the GIS Weasel (Viger and Leavesley 2007), a GIS tool that delineates watershed areas using digital elevation models for the areas of interest. In all cases, WA does not include the LA within the watershed.

Statistical analyses

We then used structural equation modeling (SEM) to investigate the interactions and causal pathways that influence PR in our dataset (e.g., Grace 2006). Although methods exist for dealing with missing values in SEM, there are often important assumptions about whether or not these observations are missing at random (Allison 2003). To reduce potential bias caused by missing values, we constructed a working dataset that had a complete set of estimates for WA, LA, Chl-*a*, temperature, DOC, SRP,

Table 1. Summary of predictor and response variables of the data presented in this manuscript. Lake area = LA, watershed area = WA, chlorophyll *a* = Chl-*a*, temperature = Temp, planktonic respiration = PR, soluble reactive phosphorus = SRP, mean value = mean, standard deviation = SD, minimum value = min, median value = median, maximum value = max.

| | LA (km ²) | WA (km ²) | Chl- <i>a</i> (mg L ⁻¹) | Temp (°C) | DOC (μM) | PR (μM O ₂ h ⁻¹) | SRP (μM) |
|---------------|-----------------------|-----------------------|-------------------------------------|-----------|----------|---|----------|
| mean | 1870.4 | 7636.1 | 7.7 | 22.4 | 728.5 | 0.6 | 406.9 |
| SD | 12 376.4 | 49 963.4 | 14.1 | 3.50 | 333.6 | 0.5 | 887.2 |
| min | 0.1 | 0.1 | 0.3 | 14.0 | 66.7 | 0.1 | 5.0 |
| median | 1.4 | 14.1 | 3.9 | 23.9 | 680.4 | 0.5 | 65.0 |
| max | 82 100.0 | 331 520.0 | 71.8 | 26.0 | 1893.3 | 2.2 | 3831.0 |

and PR, resulting in a dataset with 60 complete observations (Supplementary Table S1).

For some of the statistical models for specific nodes (i.e., LA), sample size was <60 because Lake Superior was sampled on multiple dates in a number of different places, whereas all other lakes in the dataset were only sampled once. For all within-lake and biological variables, there was temporal variation among the samples but no variation among the landscape-level parameters (i.e., LA and WA). Therefore, for fits in which landscape-level parameters were treated as responses, Lake Superior is treated as a single measurement, reducing sample size from 60 to 44.

Our strategy for fitting the *a priori* causal network hypothesis (Fig. 2b) follows the local-estimation procedure described for SEM (Grace et al. 2012). All variables were log₁₀ transformed to linearize the hypothesized scaling relationships. As a result, the parameter estimates of the slopes of the linear relationships are estimates of the scaling power. Each variable in the network was fit as a function to those variables with the arrows that point toward it (Fig. 2b). After the linear models were fit for each variable, we tested the structure of the causal network by conducting residual analysis (Grace et al. 2012). A causal network model makes a number of predictions that can be used to test the structure of the model. If the observed data were generated by the model being tested, then there should be no relationship between the residuals of any pair of variables not directly connected by an arrow. Such variables are referred to as D-separated (Shiple 2000) and are testable implications of causal network models (Pearl 2000). Testing the set of D-separation statements of a causal graph allows both the quantification of the statistical support for the causal hypotheses as a whole (via the Fisher's combined test, with test statistic *C*, in a procedure called the D-sep test; *sensu* Shiple 2000) and the identification of missing relationships in our initial causal model. The *p*-value of the D-sep test can be usefully interpreted as the probability that the data were generated by the given causal network. We then evaluated the results of the residual analysis, and if necessary, modified the causal

network to account for any residual relationships and refit the model. We eliminated relationships (arrows) with little statistical support from the causal network and refit the reduced model to arrive at the final data-implied model.

Results

The parameters used to model the relationship covered a broad range of LA, WA, trophic state, and temperature (Table 1). Our hypothesized initial causal model could not be rejected ($C = 13.55$, $df = 16$, $p = 0.632$, $AIC = 328.19$; Fig. 2b); however, analysis of the residuals revealed a strong residual relationship between SRP and temperature (Fig. 3). We therefore modified the model to include an effect of temperature on SRP. This additional relationship improved the fit of the model ($C = 4.30$, $df = 14$, $p = 0.993$, $AIC = 323.59$). We then removed all paths that did not have significant support from the data with the exception of one path, the effect of SRP on PR, which was only marginally insignificant ($p = 0.06$). Based on the strong prior support for the existence of the relationship between phosphorus and PR (e.g., Smith and Prairie 2004), and because it was marginally significant in our analysis, we retained this effect within the model structure. The lack of other residual relationships among variables suggested that all significant relationships were represented in the structure of the final model. Thus, the most parsimonious model with the strongest support from the data led to the best and final model fit ($C = 8.49$, $df = 20$, $p = 0.988$, $AIC = 321.84$; Fig. 4).

Screening for influential variables indicated that Lake Superior was an influential site only in the fit for LA as a function of WA (Appendix I), and although not statically problematic, the degree to which parameter estimates depend on potentially influential points are often of interest. In this case, we attempted to quantify the influence of Lake Superior in 2 ways: using robust regression and using standard regression with the potentially influential point removed. We found that using M-estimates of robust regression (Huber 1964) changed the parameter estimates little (Table 2, Fig. 5).

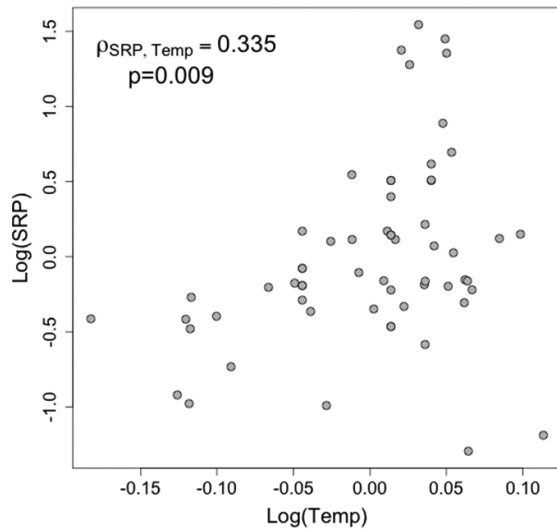

Fig. 3. The residuals from the *a priori* model for the relationship between temperature (°C) and SRP (µM). This relationship suggests that the *a priori* model should be amended to include a relationship from SRP to temperature.

Discussion

In general, model fits supported the scaling relationships derived from first principles with both size (>1 or <1) and direction (+ or -) of the scaling coefficient matching predictions. The effect of WA on both within lake parameters and subsequently PR was mediated through LA, suggesting that dilution played a more important role than delivery in controlling the parameters that affected PR. Specifically, we found that LA affected PR through direct effects on DOC and temperature and indirectly through SRP (Fig. 4). Scale coefficients for the relationship between LA and chemical (DOC and SRP) and physical (temperature) parameters were found to be negative and have absolute values <1, consistent with our predictions. Biological processes scaled positively with physical and chemical parameters with magnitudes and directions that were predicted from theory and/or previous studies, as discussed earlier (i.e., temperature >1, others <1).

The single exception to the predicted scaling relationships was the relationship between SRP and Chl-*a*, which scaled negatively, the opposite of that predicted. At first glance, this result seems to contradict the well-established relationship between P and algal biomass (Vollenweider 1968); however, SRP is not always proportional to total phosphorus (TP) or even total dissolved phosphorus (TDP; see table 13-2 in Wetzel 2001), the 2 most commonly used metrics for P content of aquatic ecosystems. Although systems with high TP and TDP on average are likely to have higher SRP, SRP is not necessarily representative of P use within an ecosystem. Rather, SRP represents the phosphate anion in its most available form, which is exceptionally reactive and has been shown to turnover on rapid time scales (Cotner et al. 1997). SRP can accumulate in lake ecosystems if P is available in excess of demand. For example, SRP may accumulate in systems of low algal biomass if algal growth is limited by other parameters (e.g., N or light) that have been shown to limit freshwater algal biomass (Sterner 2008). It is also possible that grazing controlled algal biomass such that lakes with higher grazing pressure had a larger SRP pool due to increased recycling from either “sloppy feeding” or increased excretion by grazers (Strom et al. 1997).

We also found significant support for a relationship between temperature and SRP (Fig. 3). The sign and magnitude of the scaling coefficient (positive and >1) and the lack of effect of landscape-level characteristics on SRP suggested that SRP was mostly controlled by in lake processes whose reactions were temperature dependent. Although as temperature increased P demand would be expected to increase (as the inhibiting effects of temperature on growth were alleviated), this reaction is unlikely for our dataset. Although temperature limits productivity of bacterial and algal production, in temperate lakes this effect is most pronounced at lower temperatures (<12 °C) and tends to be alleviated at higher (>12 °C) temperatures (Felip et al. 1996, Hall et al. 2007). Our dataset had temperatures that ranged from 14 to 26 °C,

Table 2. Final model parameter estimates for response variables that include lake area as a response or predictor variable using 3 different methods of estimation: ordinary least squares (OLS), M-estimates, and OLS minus Lake Superior (OLS-LS).

| | Lake Area~Watershed Area | | Temperature~Lake Area | | SRP~ Lake Area | | DOC~ Lake Area | |
|---------|--------------------------|--------------|-----------------------|---------------|----------------|---------------|----------------|--------------|
| | Intercept | slope | Intercept | slope | Intercept | slope | Intercept | slope |
| OLS | -0.669 | 0.724 | 1.35 | -0.033 | 2.008 | -0.069 | 2.85 | -0.14 |
| M-Est | -0.573 | 0.645 | 1.36 | -0.034 | 1.912 | -0.041 | 2.83 | -0.14 |
| OLS-LS* | 0.486 | 0.54 | 1.35 | -0.024 | 2.037 | -0.476 | 2.84 | -0.03 |

*-LS indicates removal of Lake Superior data

Bold values indicate estimate is significantly different than zero ($p > 0.05$)

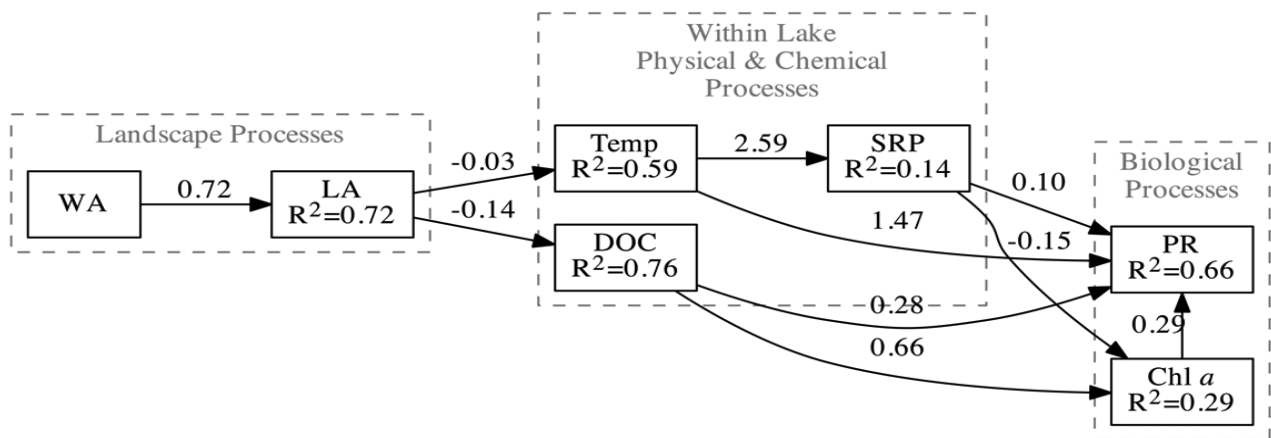

Fig. 4. Final models selected from empirical measurement and a priori scaling arguments. Numbers on arrows are fitted values for the scale coefficients. The numbers in the boxes are the R² for that variable that are measurements, products, or indicators of the processes indicated by each type of process.

beyond the range where temperature has the most pronounced effects on organismal growth. Conversely, temperature has been shown to have a pronounced effect on the mineral content of a wide range of organisms, with warmer temperatures resulting in decreased biomass P content and thus decreased organismal P demand (Wood et al. 2002, Cotner et al. 2006, Hall et al. 2009). Because lake concentrations of SRP have been shown to be inversely related to bacterioplankton biomass P:C (Hall et al. 2011), increasing temperature may result in accumulation of SRP in the water column due to decreased planktonic P demand.

Another factor that may have potentially influenced the temperature to SRP relationship was P regeneration from the sediments (Suplee and Cotner 2002). A subset of the lakes included in this analysis were relatively shallow, and some only stratified occasionally or may not have stratified at all during the ice-free season. In shallow systems with relatively large sediment–water interface areas, temperature has been shown to have a strong effect on P release from sediments (Jensen and Anderson 1992, Nichols 1999, Suplee and Cotner 2002). This mechanism may have also contributed to the observed positive correlation between temperature and SRP. If this mechanism was in part responsible for the observed SRP–temperature relationship, the negative relationship between LA and temperature suggests that sediment P regeneration may play an increasingly important role in P supply in smaller lakes. Thus, while the relationships with SRP (both with Chl-*a* and temperature) were not predicted *a priori*, the strength and direction of the relationships found within the model are consistent with previously documented mechanisms for P cycling in freshwater ecosystems.

As noted earlier, a direct relationship between WA and any of the chemical or biological parameters was not supported by the current analysis. However, we found evidence that it did affect these parameters indirectly through its strong effect on LA, which was significantly related to both temperature and DOC (Fig. 4), both of which directly affected PR. The relationship between WA, LA, and these parameters is consistent with our current understanding of how allochthonous subsidies influence aquatic metabolism. It has been well established that allochthonous loading of substrates most likely stimulates PR through 2 principal mechanisms. First, DOC can directly stimulate bacterial contribution to PR. On average, bacterial respiration contributes half of PR but can be as much as 90% in oligotrophic ecosystems (Biddanda et al. 2001). Although it has been assumed that terrigenous organic matter was fairly recalcitrant, there is increasing evidence that it can be quite labile (Mann et al. 2012, Wickland et al. 2012) and therefore a significant source of heterotrophy in temperate lakes.

Second, DOC inputs were likely accompanied by a broad range of terrestrial inputs including not only C, but also sources of N and P (both organic and inorganic) that fueled both algal and bacterial metabolism. Stimulation of algal biomass by allochthonous subsidies is consistent with the strong positive relationship between DOC and Chl-*a* present in the final model (Fig. 4). For a single system, it has been shown that DOC loading can have a negative effect on Chl-*a* concentrations due to shading of photosynthesis by colored DOC (Christensen et al. 1996). In this analysis, however, we observed only a positive relationship between DOC and Chl-*a* (Fig. 4). A study of some of the lakes in our study area (north-central Minnesota) but not included in this analysis showed that

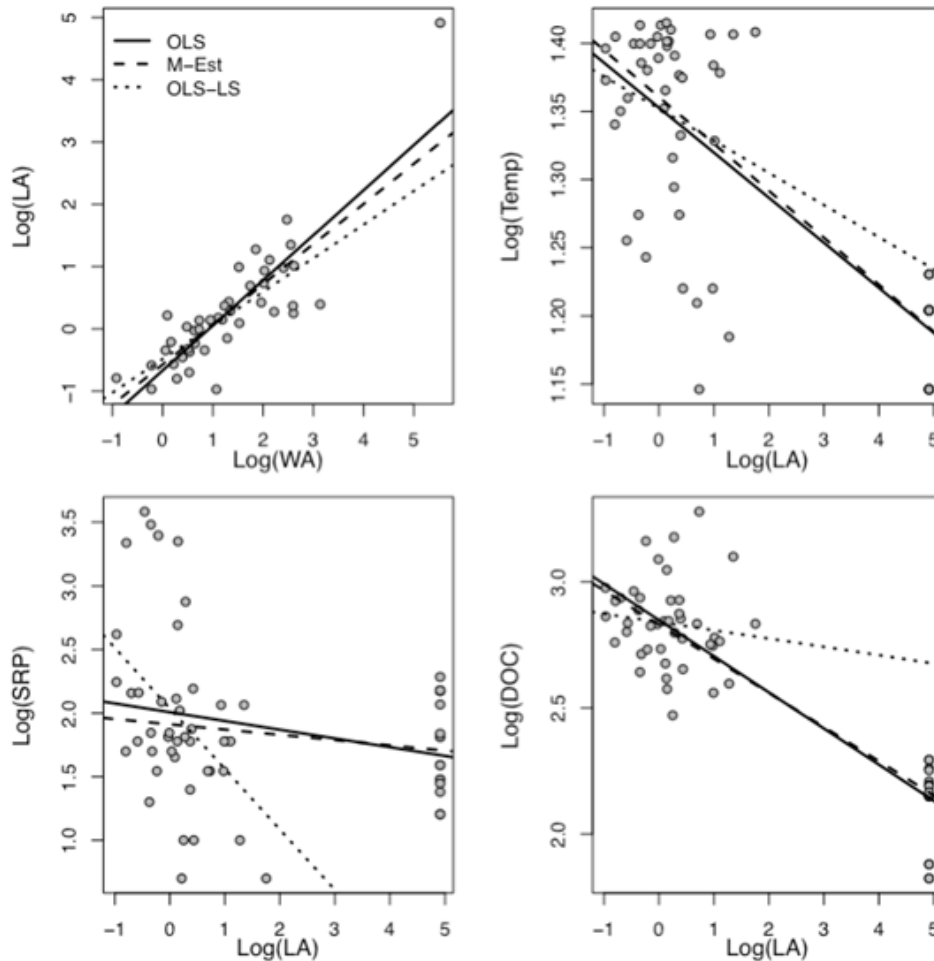

Fig. 5. Results of fitting the models that include Lake Area (LA) as a response or predictor variables to examine the effect of Lake Superior on estimated parameters using Ordinary Least Squares (solid), M-estimate (dashed), and Ordinary Least Squares with Lake Superior sites removed (dotted). Details on the different methods are discussed in Appendix 1. All variables have been log transformed with units as described in Table 1.

internal DOC loading made up a large portion of BR (Stets et al. 2010). Our results also contrast with another survey examining Chl-*a*, DOC, and respiration in which a negative relationship between DOC and Chl-*a* was observed, likely driven by the highly colored nature of DOC in Canadian Shield lakes (del Giorgio and Peters 1994). Light absorption due to higher DOC levels can also drive an increase in Chl-*a* to biomass ratio, however, resulting in increased Chl-*a* measurements without an increase in planktonic biomass (Carpenter et al. 1998). In the current survey, the specific ultraviolet absorbance (SUVA) reported for the great majority of lakes was much lower than that for the Canadian lakes (data not shown), suggesting that shading of phytoplankton was likely much less important.

Although the complete set of relationships relating landscape-level characteristics to within lake respiration are complex, here we show predictable patterns among drivers of PR for a wide range of lake ecosystems. We

were able to successfully predict the shape (i.e., sign and magnitude) of the nonlinearities between these relationships based on simple geometric arguments, suggesting that geometric relationships at least constrain these relationships over a large range of environmental characteristics and spatial scales.

In conclusion, our analysis of respiration in 44 temperate aquatic ecosystems found that aquatic respiration was best predicted by relatively few within-lake parameters. These parameters explained the great majority (66%) of variance in respiration among aquatic ecosystems ranging from shallow lakes to Lake Superior. The analyses presented here provide robust support to estimate the relationships among drivers of PR. With estimates of few environmental and landscape parameters, this relatively simple framework has the potential to estimate constraints on the contribution of PR in temperate aquatic ecosystems to the global carbon cycle over broad spatial scales.

Acknowledgements

AMA and JBC are thankful to the R/V Blue Heron Crew for field help and AMA to CNPq-Brazil for the SPS. A portion of this work was supported by the National Science Foundation under grant number OCE-0527196, DEB-0842441 to JTL and SEJ; and DEB-0519041 and OCE-0527196 to JBC. J. Clasen, H. Hendrixson, K. Land, S. Thompson, A. Warren, D. Weedman, and M. Zylstra provided invaluable assistance with sampling and fieldwork.

References

- Allison PD. 2003. Missing data techniques for structural equation modeling. *J Abnorm Psychol.* 112:545–557.
- [APHA] American Public Health Association. 1992. Standard methods for the examination of water and wastewater. 18th ed. Washington (DC).
- Battin TJ, Kaplan LA, Findlay S, Hopkinson CS, Marti E, Packman AI, Newbold L, Sabeter F. 2008. Biophysical controls on organic carbon fluxes in fluvial networks. *Nat Geosci.* 1:95.
- Battin TJ, Luysaert S, Kaplan LA, Aufdenkampe AK, Richter A, Tranvik LJ. 2009. The boundless carbon cycle. *Nat Geosci.* 2:598–600.
- Biddanda B, Ogdahl M, Cotner J. 2001. Dominance of bacterial metabolism in oligotrophic relative to eutrophic waters. *Limnol Oceanogr.* 46:730–739.
- Canham C, Pace ML, Papik MJ, Primack AGB, Roy KM, Maranger RJ, Curran RP, Spada DM. 2004. A spatially explicit watershed-scale analysis of dissolved organic carbon in Adirondack lakes. *Ecol Appl.* 14:839–854.
- Carpenter SR, Cole JJ, Kitchell JF, Pace ML. 1998. Impact of dissolved organic carbon, phosphorus, and grazing on phytoplankton biomass and production in experimental lakes. *Limnol Oceanogr.* 43:73–80.
- Christensen DL, Carpenter SR, Cottingham KL, Knight SE, LeBouton JP, Schindler DE, Voichick N, Cole JJ, Pace ML. 1996. Pelagic responses to changes in dissolved organic carbon following division of a seepage lake. *Limnol Oceanogr.* 41:553–559.
- Cole JJ, Prairie YT, Caraco NF, McDowell WH, Tranvik LJ, Striegl RG, Duarte CM, Kortelainen P, Downing JA, Middelburg JJ, Melack J. 2007. Plumbing the global carbon cycle: integrating inland waters into the terrestrial carbon budget. *Ecosystems.* 10:171–184.
- Cotner JB, Ammerman JW, Peele ER, Bentzen E. 1997. Phosphorus-limited bacterioplankton growth in the Sargasso Sea. *Aquat Microb Ecol.* 13:141–149.
- Cotner JB, Biddanda BA. 2002. Small players, large role: microbial influence on biogeochemical processes in pelagic aquatic ecosystems. *Ecosystems.* 5:105–121.
- Cotner JB, Makino W, Biddanda BA. 2006. Temperature affects stoichiometry and biochemical composition of *Escherichia Coli*. *Microb Ecol.* doi:10.1007/s00248-006-9040-1
- Cotner JB, Wetzel RG. 1991. 5'-nucleotidase activity in a eutrophic lake and an oligotrophic lake. *Appl Environ Microbiol.* 57:1306.
- del Giorgio PA, Peters RH. 1994. Patterns in planktonic P:R ratios in lakes: influence of lake trophy and dissolved organic carbon. *Limnol Oceanogr.* 39:772–787.
- Dillon PJ, Molot LA. 1997. Effect of landscape form on export of dissolved organic carbon, iron, and phosphorus from forested stream catchments. *Water Resour Res.* doi:10.1029/97WR01921
- Downing JA, Prairie YT, Cole JJ, Duarte CM, Tranvik LJ, Striegl RG, McDowell WH, Kortelainen P, Caraco NF, Melack JM, Middelburg JJ. 2006. The global abundance and size distribution of lakes, ponds and impoundments. *Limnol Oceanogr.* 51:2388–2397.
- Enquist BJ, Brown JH, West GB. 1998. Allometric scaling of plant energetics and population density. *Nature.* 395:163–166.
- Felip M, Pace ML, Cole JJ. 1996. Regulation of planktonic bacterial growth rates: the effects of temperature and resources. *Microb Ecol.* 31:15–28.
- Ginzburg L, Colyvan M. 2004. Ecological orbits: how planets move and populations grow. New York: Oxford University Press.
- Grace JB. 2006. Structural equation modeling and natural systems. Cambridge University Press. 365 p.
- Grace JB, Schoolmaster DR Jr, Guntenspergen GR, Little AM, Mitchell BR, Miller KM, Schweiger EW. 2012. Guidelines for graph-theoretic implementation of structural equation modeling. *Ecosphere.* 3:1–44.
- Gudasz C, Basktviken D, Steger K, Premke K, Sobek S, Tranvik LJ. 2010. Temperature-controlled organic carbon mineralization in lake sediments. *Nature.* 466:478–481.
- Hall EK, Cotner JB. 2007. Interactive effect of temperature and resources on carbon cycling by freshwater bacterioplankton communities. *Aquat Microb Ecol.* 49:35–45.
- Hall EK, Dzialowski AR, Stoxen SM, Cotner JB. 2009. The effect of temperature on the coupling between phosphorus and growth in lacustrine bacterioplankton communities. *Limnol Oceanogr.* 54:880–889.
- Hall EK, Maixner F, Franklin O, Daims H, Richter A, Battin T. 2011. Linking microbial and ecosystem ecology using ecological stoichiometry: a synthesis of conceptual and empirical approaches. *Ecosystems.* 14:261–273.
- Hamilton SK, Melack JM, GoodChild MF, Lewis WM. 1994. Estimation of the fractal dimensions of terrain from lake size distributions. In: Carling PA, Petts GE, editors. Lowland floodplain rivers: geomorphological perspectives. John Wiley & Sons.
- Hanson PC, Bade DL, Carpenter SR, Kratz TK. 2003. Lake metabolism: relationships with dissolved organic carbon and phosphorus. *Limnol Oceanogr.* 48:1112–1119.
- Huber PJ. 1964. Robust estimation of a location parameter. *Ann Math Stat.* 35:73–101.
- Jensen HS, Anderson F. 1992. Importance of temperature, nitrate, and pH for phosphate release from aerobic sediments of four shallow, eutrophic lakes. *Limnol Oceanogr.* 37:577–589.
- Karlsson J, Jansson M, Jonsson M. 2004. Similar relationships between pelagic primary and bacterial production in clearwater and humic lakes. *Ecology.* 83:2902–2910.

- Kalff J. 2002. *Limnology: inland water ecosystems*. New York (NY): Prentice Hall. 592 p.
- Kratz T, Webster K, Bowser C, Magnuson J, Benson B. 1997. The influence of landscape position on lakes in northern Wisconsin. *Freshwater Biol.* 37:209–217.
- Mann PJ, Davydova A, Zimov N, Spencer RGM, Davydov S, Bulygina E, Zimov S, Holmes RM. 2012. Controls on the composition and lability of dissolved organic matter in Siberia's Kolyma River Basin. *J Geophys Res-Biogeosci.* doi:10.1029/2011JG001798
- Mattsson T, Kortelainen P, Laubel A, Evans D, Pujó-Pay M, Råike A, Conan P. 2008. Export of dissolved organic matter in relation to land use along a European climatic gradient. *Sci Total Environ.* doi:10.1016/j.scitotenv.2008.11.014
- McCallister SL, del Giorgio PA. 2012. Evidence for the respiration of ancient terrestrial organic C in northern temperate lakes and streams. *P Nat Acad Sci.* doi:10.1073/pnas.1207305109
- McDonald CP, Rover JA, Stets EG, Striegl RG. 2012. The regional abundance and size distribution of lakes and reservoirs in the United States and implications for estimates of global lake extent. *Limnol Oceanogr.* 57:597–606.
- McMahon T. 1973. Size and shape in biology. *Science.* 179:1201–1204.
- Montagnes DJS, Kimmance SA, Atkinson D. 2003. Using Q10: can growth rates increase linearly with temperature? *Aquat Microb Ecol.* 32:307–313.
- Nicholls KH. 1999. Effects of temperature and other factors on summer phosphorus in the Inner Bay of Quinte, Lake Ontario: implications for climate warming. *J Great Lakes Res.* 25:250–262.
- Pace ML, Prairie YT. 2005. Respiration in lakes. In: del Giorgio P, Williams B, editors. *Respiration in Aquatic Ecosystems*. Oxford (UK): Oxford University Press.
- Pearl J. 2000. *Causality: models, reasoning, and inference*. New York: Cambridge University Press.
- Parsons TR, Maita Y, Lalli C. 1984. *A manual of chemical and biological methods for seawater analysis*. Pergamon.
- Qualls RG, Richardson CJ. 2003. Factors controlling concentration, export, and decomposition of dissolved organic nutrients in the Everglades of Florida. *Biogeochemistry.* 62:197–229.
- R Core Development Team. 2009. *R: a language and environment for statistical computing*. Reference index v2.8.1. Vienna (Austria): R Foundation for Statistical Computing. <http://R-project.org>
- Raymond PA, Hartmann J, Lauerwald R, Sobek S, McDonald C, Hoover M, Butman D, et al. 2013. Global carbon dioxide emissions from inland waters. *Nature.* doi:10.1038/nature12760
- Robin L, Vannote G, Minshall W, Cummins KW, Sedell JR, Cushing CE. 1980. The river continuum concept. *Can J Fish Aquat Sci.* 37:130–137.
- Shipley B. 2000. A new inferential test for path models based on directed acyclic graphs. *Struct Equ Modeling* 7:206–218.
- Smith EM, Prairie YT. 2004. Bacterial metabolism and growth efficiency in lakes: the importance of phosphorus availability *Limnol Oceanogr.* 49:137–147.
- Stern RW. 2008. On the phosphorus limitation paradigm for lakes. *Int Rev Hydrobiol.* 93:433–445.
- Stets EG, Cotner JB. 2008. Biodegradable dissolved organic carbon in lake ecosystems: sources and effects on planktonic respiration. *Can J Fish Aquat Sci.* 65:2454–2460.
- Stets EG, Striegl RG, Aiken GR. 2010. Dissolved organic carbon export and internal cycling in small, headwater lakes. *Global Biogeochemical Cycles.* 24:GB4008. doi:10.1029/2010GB003815
- Strom SL, Benner R, Ziegler S, Dagg MJ. 1997. Planktonic grazers are a potentially important source of marine dissolved organic carbon. *Limnol Oceanogr.* 42:1364–1374.
- Suplee MW, Cotner JB. 2002. An evaluation of the importance of sulfate reduction and temperature to P fluxes from aerobic-surfaced, lacustrine sediments. *Biogeochemistry.* 61:199–228.
- Thrane JE, Hessen DO, Andersen T. 2014. The absorption of light in lakes: negative impact of dissolved organic carbon on primary productivity. *Ecosystems.* 17:1040–1052.
- Vannote RL, Minshall GW, Cummins KW, Sedell JR, Cushing CE. 1980. The river continuum concept. *Can J Fish Aquat Sci.* 37:130–137.
- Viger RJ, Leavesley GH. 2007. Section 4. The GIS Weasel user's manual. US Geological Survey. *Techniques and Methods* 6-B4.
- Vollenweider RA. 1968. *Water management research. Scientific fundamentals of the eutrophication of lakes and flowing waters, with particular reference to nitrogen and phosphorus as factors in eutrophication*. Paris (France): Organisation for Economic Cooperation and Development. DAS/CSI/68.27. 192 p.
- West GB, Brown JH, Enquist BJ. 1997. A general model of the origin of allometric scaling laws in biology. *Science.* 276:122–126.
- Wetzel RG. 2001. *Limnology: lake and river ecosystems*. San Diego (CA): Academic Press.
- Wetzel RG, Likens GE. 2000. *Limnological analyses*. New York: Springer Verlag.
- Wickland KP, Aiken GR, Butler K, Domblaser MM, Spencer GM, Striegl RG. 2012. Biodegradability of dissolved organic carbon in the Yukon River and its tributaries: seasonality and importance of inorganic nitrogen. *Global Biogeochem Cy.* doi:10.1029/2012GB004342
- Winslow LA, Read JS, Hanson PC, Stanley EH. 2014. Does lake size matter? Combining morphology and process modeling to examine the contribution of lake classes to population-scale processes. *Inland Waters.* 5:7–14.
- Woods HA Makino W, Cotner JB, Hobbie SE, Harrison JF, Acharya K, Elser JJ. 2003. Temperature and the chemical composition of poikilothermic organisms. *Funct Ecol.* 17:273–245.